



Multistage Centrifugal Pumps

CV series

Standard design

Multistage centrifugal pumps with closed impeller for medium and high heads.

Closed coupled design with closed impellers, directly mounted on to the motor shaft.

Setting up in horizontal and vertical way for every requirement of installation.

Industrial construction with motor shroud and adjustable feet on request.

Wetted parts in CF-8M 1.4408 / AISI 316 stainless steel, investment cast and electro-chemically polished.

Flow rates up to max. 40 m³ /h, heads up to 140 m

Seals:

Mechanical seals with seats to EN 12756, ISO 3069 standards.
Single internal mechanical seal

Elastomers (certified to FDA):

EPDM
Fluorocarbon (Viton)
Silicone
P.T.F.E. (FEP)

Connections:

DIN - SMS - IDF - BS / RJT - DS - CLAMP and EN 1092-1 PN16 flanges to suit most international standards.

Applications

Suitable for industrial or foodstuffs applications where 316 stainless is necessary, but without any particular cleaning or sterility requirements.

These remarkably sturdy and cost effective pumps are perfect for applications where hygiene is of low importance.

The closed impellers are not able to handle products which contain solids or highly viscous liquids.

Widely used in:

- Cleaning & washing systems
- Fluid Filtration
- General Transfer
- Feeding
- Water treatment

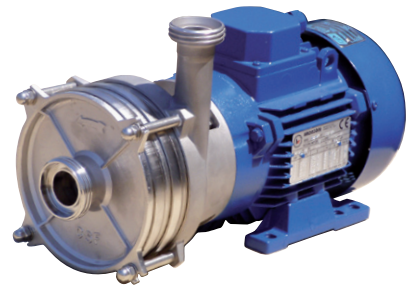

Horizontal multistage CV 11...18 pumps



Multistage CV 11...18 pumps vertical exec.

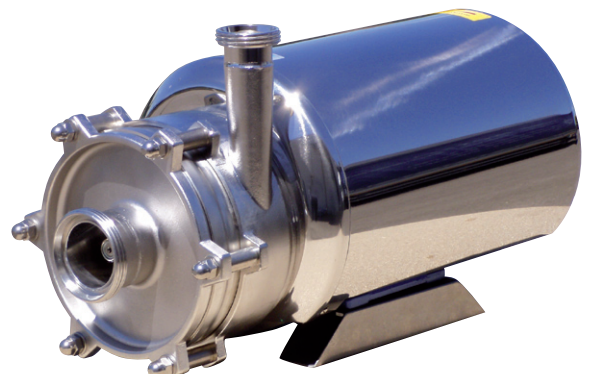

Multistage CV 52...82 pumps with shroud

GENERAL DIAGRAMS

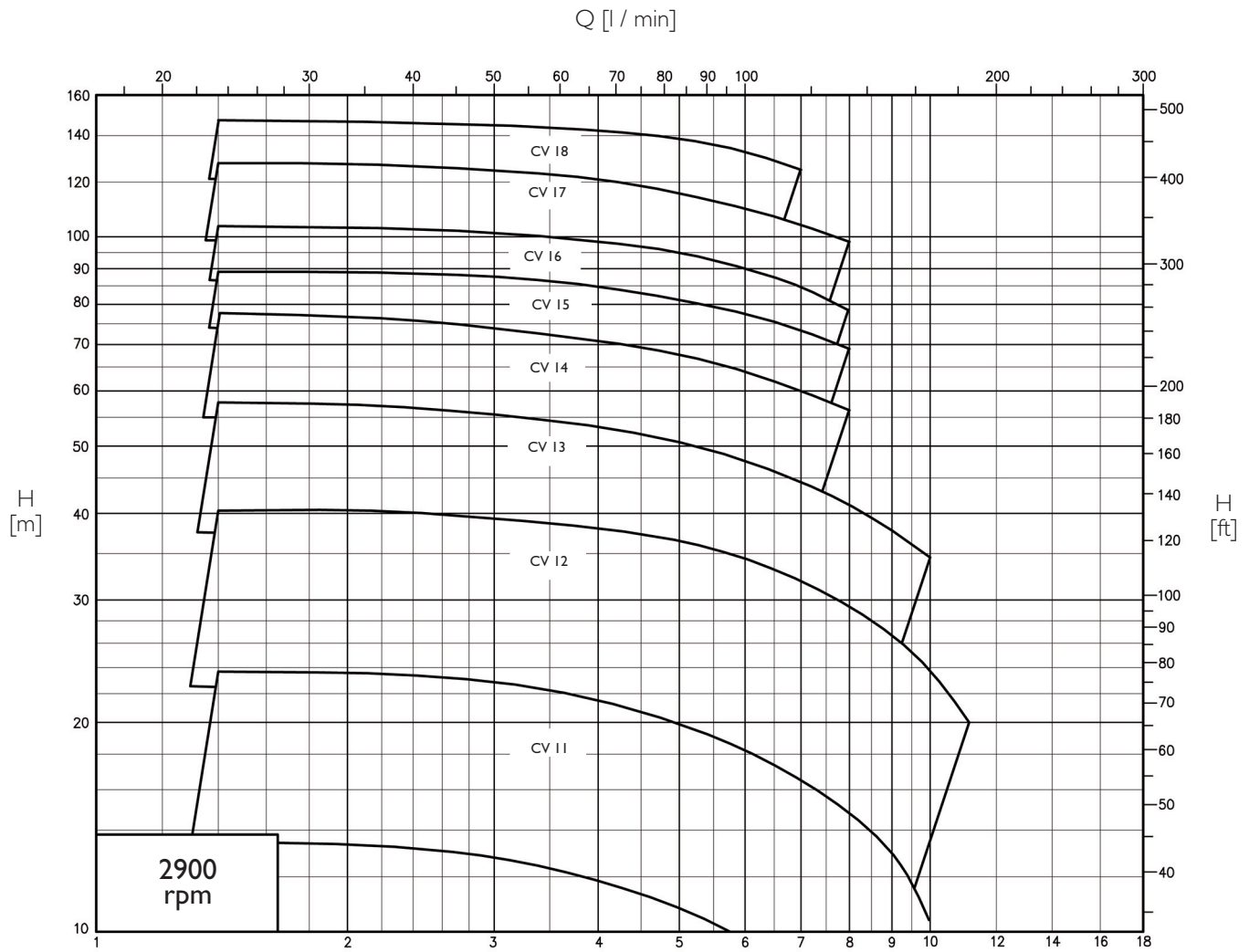

Performance applies to H₂O at 20 °C, 1013 millibar

Q [m³ / h]

Data not binding

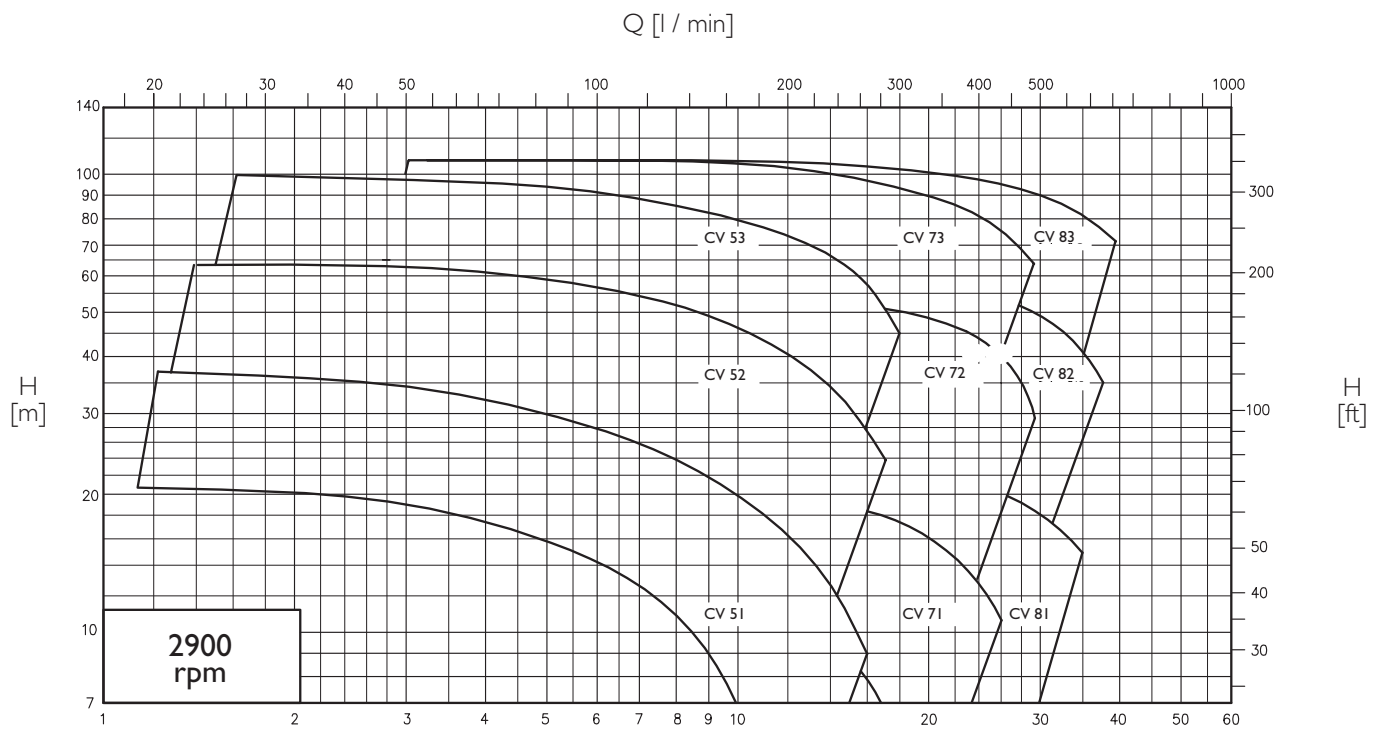

Performance applies to H₂O at 20 °C, 1013 millibar

Q [m³ / h]

Data not binding

OVERALL DIMENSIONS

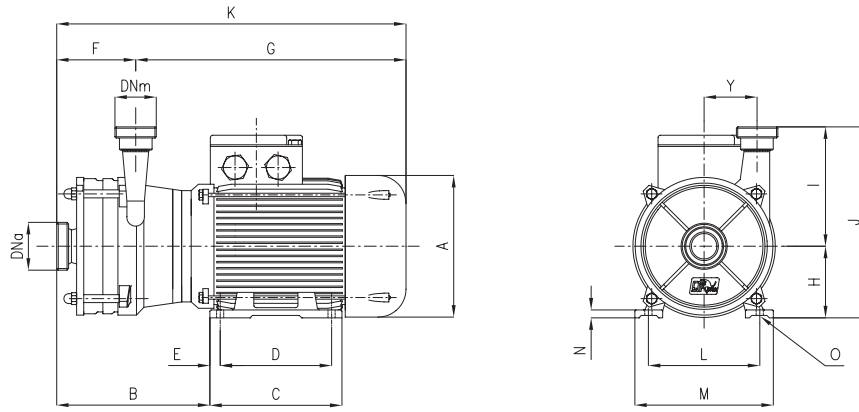

Dimensions not binding - DN = DIN 11851 male threaded connections

Pumps	2900 rpm	kW	DNa	DNm	A	B	C	D	E	F	G	K	H	J	I	L	M	N	O	P	Y
CV 11		1,1	32	25	162	155	118	100	9	56	314	370	90	240	150	125	150	8	9,5	-	65
CV 12		1,5	32	25	181	182	143	100	12,5	80	314	394	90	240	150	140	165	10	10	-	65
CV 13		2,2	32	25	181	206	143	100	12,5	104	337	441	90	240	150	140	165	10	10	-	65
CV 14		3	32	25	202	236	176	140	13	128	337	465	100	240	150	160	196	12	12	-	65

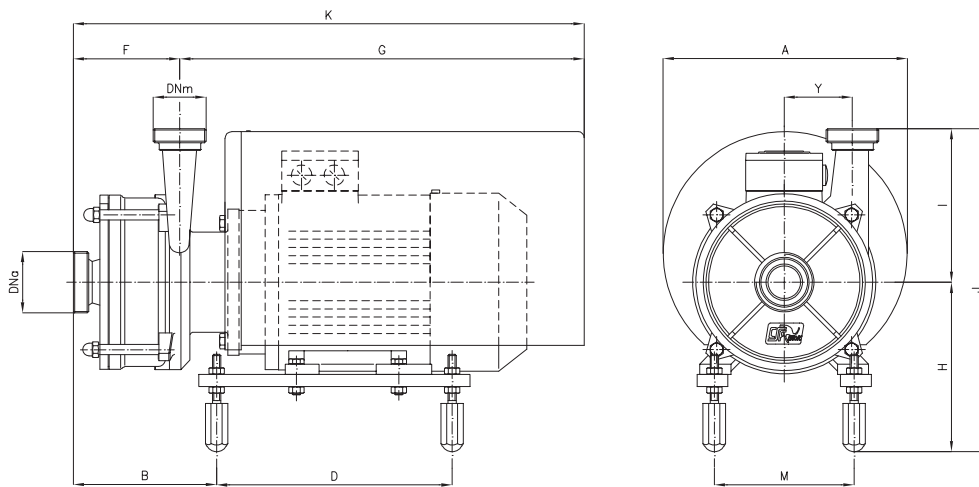

Dimensions not binding - DN = DIN 11851 male threaded connections

Pumps	2900 rpm	kW	DNa	DNm	ØA	B	D	F	G	H	I	K	J	M	Y
CV 11		1,1	32	25	238,5	92	230	56	395	178	150	451	315	136,5	65
CV 12		1,5	32	25	238,5	118	230	80	395	178	150	477	315	136,5	65
CV 13		2,2	32	25	238,5	140	230	104	395	178	150	499	315	136,5	65
CV 14		3	32	25	238,5	164	230	128	395	178	150	523	315	136,5	65

Outlet port position
ref. a = standard exec.
ref. b-c-d = exec. on request

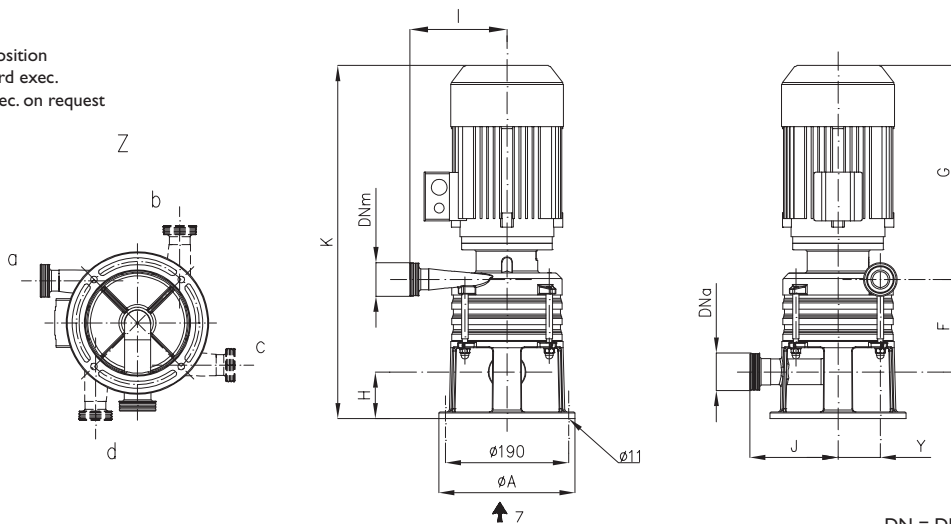

Dimensions not binding -
DN = DIN 11851 male threaded connections

Pumps	2900 rpm	kW	DNa	DNm	A	F	G	H	I	J	K	Y
CV 11V		1,1	32	25	220	69	316	71	150	136	456	65
CV 12V		1,5	32	25	220	93	316	71	150	136	480	65
CV 13V		2,2	32	25	220	117	346	71	150	136	534	65
CV 14V		3	32	25	220	141	346	71	150	136	558	65
CV 15V		4	32	25	220	165	371	71	150	136	607	65
CV 16V		4	32	25	220	189	371	71	150	136	631	65
CV 17V		5,5	32	25	220	213	386	71	150	136	670	65
CV 18V		5,5	32	25	220	237	386	71	150	136	694	65

OVERALL DIMENSIONS

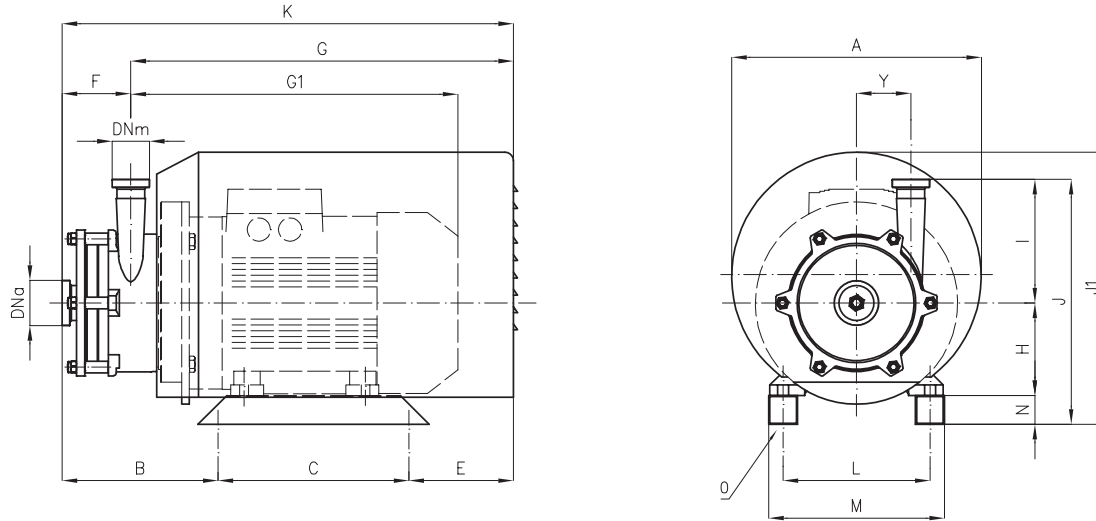

Dimensions not binding - DN = DIN 11851 male threaded connections

Pumps	kW	DNa	DNm	ØA	B	C	E	F	G	GI	H	I	J	J1	K	L	M	N	O	Y
CV 51	2,2	50	40	298	186,5	200	107,5	80	414	378	90	214	344	294	494	140	180	40	10	94
CV 52	4	50	40	330	232	230	141	119	484	403	100	214	364	355	603	160	210	50	12	94
CV 53	7,5	50	40	372	271	230	141	158	484	418	112	214	376	367	642	190	240	50	12	94
CV 71	4	50	40	330	193	230	141	80	484	403	100	214	364	355	564	160	210	50	12	94
CV 72	7,5	50	40	372	232	230	141	119	484	418	112	214	376	367	603	190	240	50	12	94
CV 73	11	50	40	372	287	266	132	158	527	469	132	214	406	415	685	216	276	60	12	94
CV 81	5,5	65	40	330	198	230	141	85	484	418	112	214	376	367	569	190	240	50	12	94
CV 82	11	65	40	372	253	266	132	124	527	469	132	214	406	415	651	216	276	60	12	94
CV 83	18,5	65	40	372	292	266	187	163	582	524	132	214	406	415	745	216	276	60	12	94

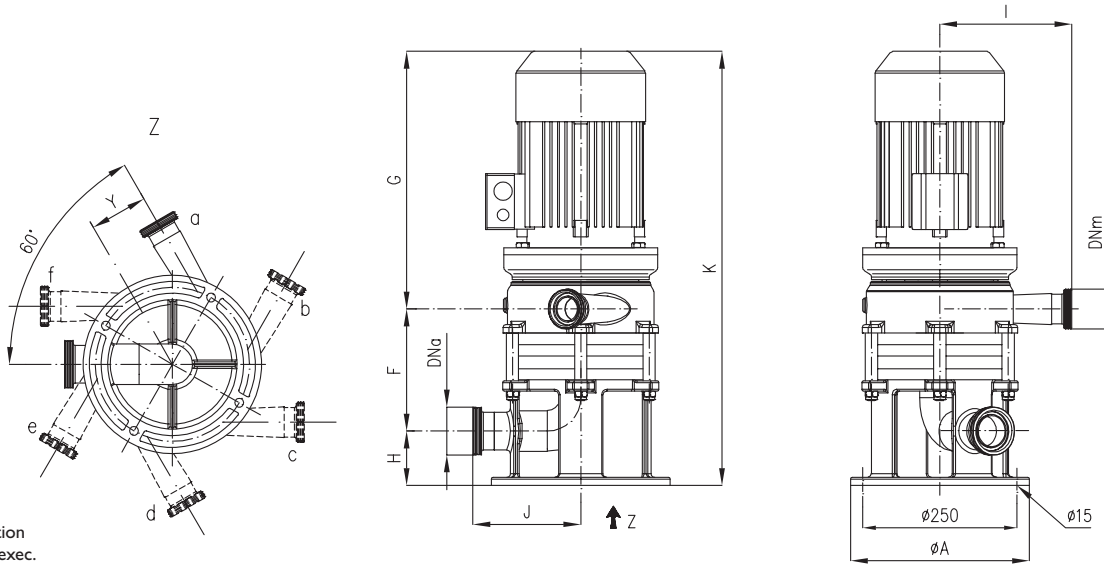

Outlet port position
ref. a = standard exec.
ref. b-c-d-e-f = exec. on request

Dimensions not binding - DN = DIN 11851 male threaded connections

Pumps	kW	DNa	DNm	ØA	F	G	H	I	J	K	Y
CV 51 V	2,2	50	40	290	120	378	88	214	175	586	94
CV 52 V	4	50	40	290	159	403	88	214	175	650	94
CV 53 V	7,5	50	40	290	198	418	88	214	175	704	94
CV 71 V	4	50	40	290	120	403	88	214	175	611	94
CV 72 V	7,5	50	40	290	159	418	88	214	175	665	94
CV 73 V	11	50	40	290	198	511	88	214	175	797	94
CV 81 V	-	-	-	-	-	-	-	-	-	-	-
CV 82 V	-	-	-	-	-	-	-	-	-	-	-
CV 83 V	-	-	-	-	-	-	-	-	-	-	-



DEWAELE TECHNICAL AGENCIES
Hazewindstraat 71
B-3540 DEERLUK
T +32 (0)56 73 5671
bernardcallens@dt-industrial.be
www.dta-pompen.com



CSF Inox S.p.A. Strada per Bibbiano, 7 - 42027 Montecchio E. (RE) - ITALY EU
Ph +39.0522.869911 ra. - Fx +39.0522.865454 / 866758 - csfitalia@csf.it - www.csf.it

Export Department • Commercial Étranger • Comercial Extranjero
Ph +39.0522.869922 - Fx +39.0522.869841 - csfexport@csf.it - www.csf.it

All the instructions, data and representations (in whatever way executed) listed in this publication are indicative and do not binding. CSF does not stand surety or undertake any obligation for the utilisation of this document and for the information contained. In particular, it does not guarantee against omissions or errors of the data and drawings here indicated.
Notice that the technical specifications, information and representations in this document are merely indicative and approximate. CSF INOX reserves the right at any moment and without notice to modify the data, drawings and information indicated in this document.